

mada  
gypsum  
مصنع للجبس

# Company Profile

Part Of

ALRAJHI  
Building Solutions Group  
مجموعة الراجحي لحلول البناء



# OUR BRANCHES

## Sales & Marketing Office In Saudi Arabia & Other Countries

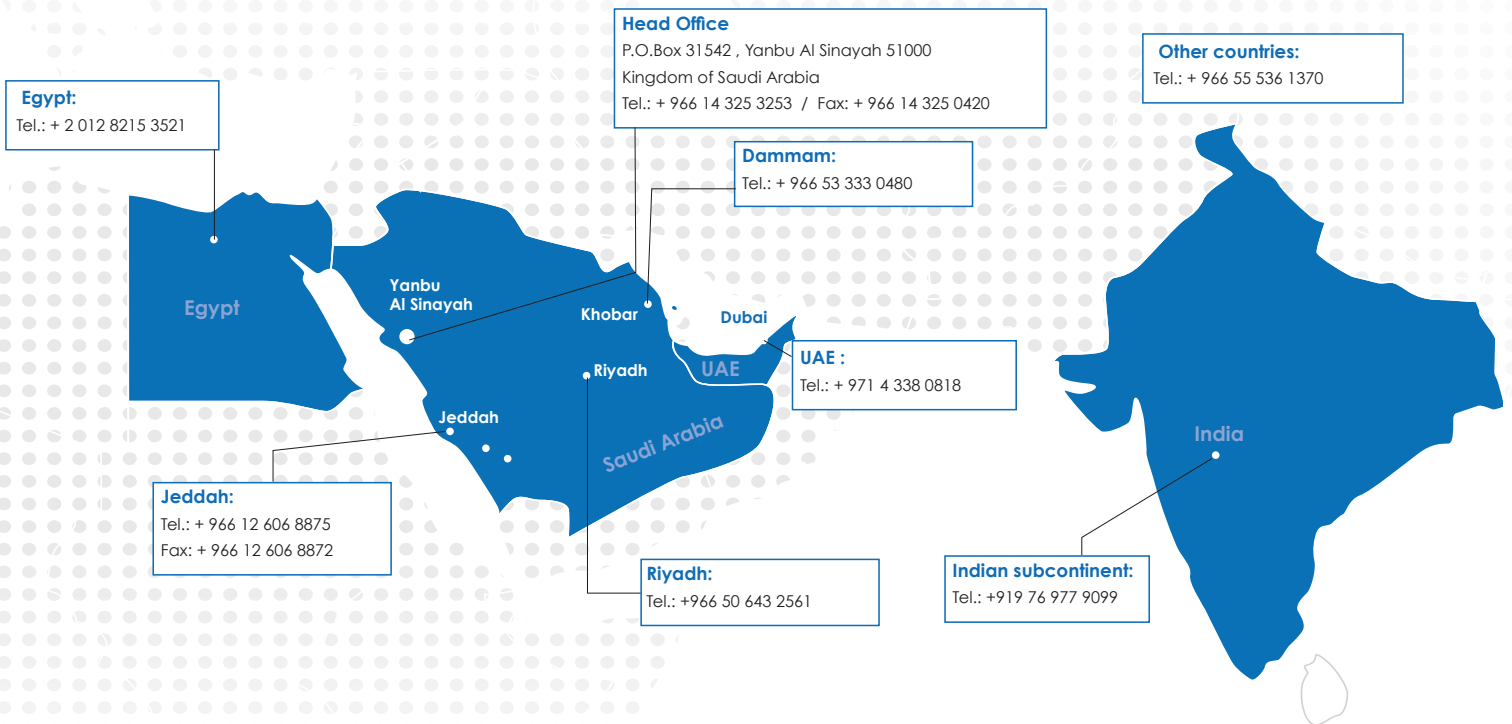

# ABOUT MADA GYPSUM COMPANY

Mada Gypsum Company (MGC) is a member Al Rajhi Building Solutions, which is a sector under the roof of Al Rajhi Holding. MGC was established in 2008 in Yanbu Industrial City with an initial factory setup consisting of a 10Mm<sup>2</sup>/yr plasterboard line and a 140,000t/yr calcination and plaster plant. Over the past eight years the capacity of plasterboard and stucco has been extended and new products were added to the product portfolio. MGC currently has a production capacity of 400,000t/yr of plasters, 42Mm<sup>2</sup>/yr of gypsum wallboard with two board lines, 2Mm<sup>2</sup>/yr of cement boards, besides production capacity of laminated gypsum ceiling tiles, dry mix and wet mix products. Production uses natural gypsum extracted in the north of the Yanbu area and flash calcining process to produce stucco. The wallboard lines are equipped with state-of-the-art control equipment to ensure full compliance with health and safety and quality standards.



## Our Mission

Educate and develop the market for Dry Lining systems and solutions while developing the DIY market and converting the old brick wall tradition into a new state of the art dry lining.

## Our Vision

MGC aims to be the most competitive & diversified supplier of Gypsum boards and related products in the MENA region, creating value for all stakeholders.

## Quality

MGC employs strict quality control process with the help of state of the art in-house laboratory to make sure our customer receives the best quality at all times. Our products are also certified by some of the world's leading laboratories and is ISO 9001 certified. MGC has also implemented WCM (World Class Manufacturing) process to improve all steps of the production process, ensuring a stable production at the highest standards.





## Our Gypsum Quarry

MGC's pursuit of excellence led to the decision of owning and operating its own gypsum quarry. Based on a complete geological study, MGC set up a mining plan that helps identify the areas to be excavated. Once excavated, a Moisture Analyzer device in the quarry checks the quality of the gypsum, which is sent to the factory once it is approved. Once in the factory, the gypsum undergoes more tests, before and after the crushers. All of these processes guarantee that only the highest quality raw materials, which reach up to 98% purity, and 95% whiteness, are used in the manufacturing of our products.



## Environmental Responsibility

MGC is committed to establish & maintain high standards of EHS (Environment – Health – Safety). MGC invested recycling technologies to help preserve the environment, while installing an ammonium scrubbing line to remove 100% of the sulphur from flue gases.



## State of the art technology

MGC employs state of the art Gyptech manufacturing equipment, a world leader in Plasterboard equipment, to produce the best quality of Plasterboard. In addition, MGC uses Grelbex and Claudius Peters calcinations to ensure the best quality of input raw material.

# HISTORY OF GYPSUM

Gypsum has been used as a building material through history. It has been used in one of the greatest achievements of mankind, the Pharaoh's Pyramids, and is still visible even after 5,000 years showcasing the durability of gypsum as a building material.



In the 18th Century, Antoine Laurent Lavoisier, a French chemist, began the study of gypsum by studying its chemical properties. Gypsum was found in great amounts near Paris, France, gaining popularity as a building material called "Plaster of Paris" or "French Plaster". Gypsum was also used by French farmers to improve crop yields by using it as a soil additive.

Late in the 19th Century, Augustine Sackett patented the "Sackett Board", where it was created by adding thin layers of "Plaster of Paris" between wool felt papers. The Sackett Board was used as a replacement for wood. Gypsum plaster was mixed with fiber and was used as the exterior of the World's Columbian Exposition palace in Chicago in 1893. By 1916, the product reached a ready-to-finish board to use in construction, reaching a very similar state to the modern plaster-board.

## Manufacturing Process

MGC owns its own quarry to guarantee the highest quality gypsum rocks in the production process and extract raw materials, which reach up to 98% purity and 95% whiteness. After crushing, gypsum will then be calcined in a flash calciner or rotary kiln to produce stucco.

For plasterboard production, stucco, water and additives are mixed into a slurry, which is sandwiched between two layers of plasterboard liner, left to set and dried in a longitudinal drier, before trimming and packing according to the product requirements.

For plaster products, the stucco will be mixed with the necessary additives, when required, and bagged before being loaded directly on flat bed trailers or palletised. Quality controls throughout the process, from quarry to loading of finished products, will ensure that MGC products meet internal specifications and international quality standards where applicable.

1. Feed for carton bottom site
2. Charge from Slurry with distribution at forming station
3. Feed of carton at the top
4. Setting belt
5. Cutting of board from one single strand to boards
6. Turner
7. Dryer infeed
8. Dryer
9. Dryer outfeed
10. Trimming
11. Stacking and take off

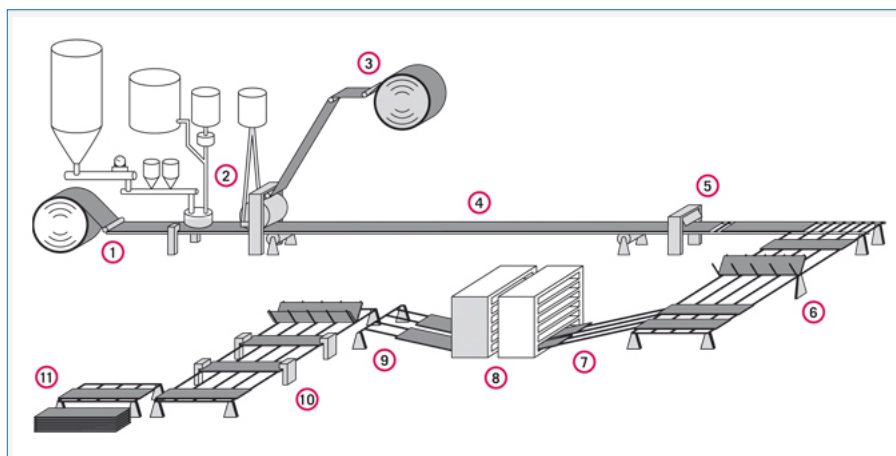

# 1. MADA PLUS SYSTEMS

Mada Plus drywall systems are non-load bearing, light in weight and easy to install. Comprising of plasterboards/cement boards screw-fixed on either side of light gauge metal structures (Tracks and Studs), sealed with joint tapes and other insulators and filled to get even smooth and homogenous surface.

Mada Plus drywall systems are offered as both standard off the shelf requirements, and tailor made according to the specifications of the project.

## \* Performance Aspects to consider while choosing a system

- \* Wall Dimensions (HxWxL)
- \* Fire resistance
- \* Acoustical resistance
- \* Impact resistance
- \* Mold resistance

## \* Performance

- \* Fire proection - up to 3hrs
- \* Sound insulation - up to 65 dB
- \* Impact Rating



## Advantages of a closed system against open systems

Acquiring all segments of a complete system from a single source (Closed Systems) guarantees the effectiveness of the system, and ensures the performance of the dry-walls as per the required standards since it was pre-tested by international laboratories around the world.

## What does the Mada system include?

|                  |               |                     |                  |            |
|------------------|---------------|---------------------|------------------|------------|
| <b>Boards</b>    | Plasterboards | Cement Boards       | Ceiling Tiles    |            |
| <b>Framing</b>   | Wall Profiles | Shaft Wall Profiles | Ceiling Profiles |            |
| <b>Finishing</b> | Screws        | Anchors             | Sealant          | Insulation |
|                  | Joint Taps    | Jointing Compound   | Plasters         | Renders    |

Our products are tested/certified by world renowned testing agencies



# MADA PLUS SYSTEMS

## BENEFITS

### **Guaranteed System Performance**

Mada Plus systems are tested at intentionally reputed 3rd party laboratories for Fire & Acoustics performance thus offering proven performance to the customer. MGC offers 10 years warranty for all its products and system performance.

### **Wide Area of Application**

Mada Plus systems cover wide area of application including hotels, educational & commercial facilities, recreational centers among others thus offering something for all needs.

### **Customized Systems**

In addition to standard applications, Mada's strong specification engineering team can work with the designers and architects of specific projects to offer systems suiting specific needs of a particular projects.

### **On Site Technical Support**

For selected locations Mada can provide onsite technical support to teach the applicators for correct application of dry wall partition to achieve system performance.

### **Recycling Facility**

Mada Gypsum Company has its own recycling facility for Plasterboard, thus offering projects additional opportunity to gain LEED points.



### **Single source of supply**

Mada Plus Systems helps drywall contractors source their complete requirement from a single source, thereby considerably reducing the complexity involved in projects. In addition, Mada ensures that different components that goes in the systems are compatible to each other, thereby ensuring performance, integrity, and longevity of the system.

### **Technical literature**

Mada Plus Systems are supported by several technical literatures (system book, system selector, installation manuals etc.) to help the project identify the right system as well as correct method of application. In addition, a wide range of typical drawings are made available to easily integrate Mada Plus Systems within the overall project masterplan.



## 2. MADA BOARDS

### Mada Plasterboards

Plasterboards are the smart modern substitute for the traditional cement/brick walls. It possesses various advantages through the ability to save space by creating thinner walls, while offering a higher rate of noise cancellation and fire resistance, it is also faster and cheaper to install. This makes Mada Plasterboards the ideal choice for your walls, ceilings, and partitions.



### Mada PROCEM

Mada PROCEM is a light weight non asbestos cement board product composed of Portland cement, light aggregate material and silica sand that is classified as A1 non-combustible. Equipping with world class manufacturing process from Europe, our board acquires the physical properties, durability and strength of cement and easy workability due to it being up to 15% lighter than other type of cement board.

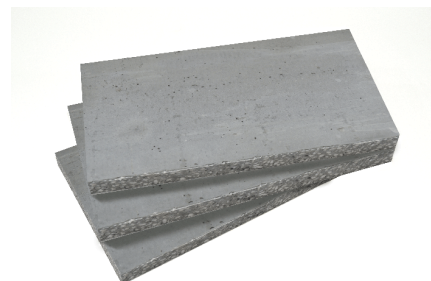

### Mada Ceiling Tiles

MGC has two ceiling tiles lines with a combined capacity of 7.5 million m2 per year. PVC Facing Gypsum Ceiling Tiles are a combination of MGC plasterboard, PVC lamination on the face, and PET aluminized foils on the back.

MGC offers various specifications for different applications and usages. PVC Facing Gypsum Ceiling Tiles are used with exposed T-Grid suspension systems in all types of buildings especially in humid areas. MGC offers 7 standard PVC patterns available in the pattern book. Other patterns are available upon request.



### Our Full Range of Borads consists of:

| Board Type                | Paper colour (Face) | Thickness                                   | Length                                 | Width                         | Edge Type |
|---------------------------|---------------------|---|--|-------------------------------|-----------|
| Regular                   | Ivory               | Standard Thicknesses :                      | Standard Lengths :                     | Standard widths :             | TE,SE,BE  |
| Fire Resistant            | Pink                | 9.5,12.5,15.0,16.0,18.0 mm                  | 2,400, 2,440, 2,800                    | 1,200 , 1220 mm               |           |
| Moisture Resistant        | Green               |   | 3,000 mm                               | Special width                 |           |
| Fire & Moisture Resistant | Green               | Special Thickness from                      | Special lengths from 1,800             | can be produced Upon          |           |
| Impact Resistant          | Yellow              | 6.5-25 mm can be produced                   | to 4,500 mm can be produced Upon       | technical evaluation          |           |
| Shaft                     | Green               | Upon technical evaluation and minimum order | technical evaluation and minimum order | and minimum order             |           |
| PROCEM                    | Gray                | 12.5 , 15.0 , 20.0 mm                       | Standard Lengths :1,800 ,2,400 mm      | Standard widths :1,200 mm     | RE        |
| Ceiling Tiles             | PVC                 | 7.0 ,8.0 , 9.5 , 12.5 mm                    | Standard Lengths :595 , 610 mm         | Standard widths :595 , 610 mm | SE        |

Our products are tested/certified by world renowned testing agencies



Intertek



مستشارية  
البحري  
STANGER

## 3. MADA FRAMES

Mada Frames are produced from cold rolled steel coils. The steel coils are hot dip galvanized using coating of Z 120 to Z 275 depending upon application. Mada Metal Profile is complying to ASTM C 645.

### 3.1 Wall Profiles

#### Mada C Stud

Mada Wall Stud is used as the vertical member of the partition system with a friction fit between the bottom and top tracks. Mada's Wall Stud features knurled faces and reinforcing ribs along the stud design. The ribs provide added strength, are less prone to twist and creating «high-shoulders» when finishing Plasterboard.

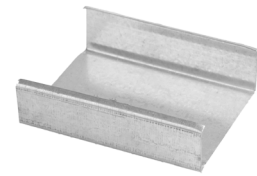

#### Mada U Track

Mada Wall Track is used at the floor and soffit to support the wall studs. Mada's Wall Track features knurled faces which is the pattern of small ridges formed on the Wall Track to prevent screws from slipping and damaging the board, without compromising the strength or thickness of the steel



#### Mada Deflection Head Track (DHT)

Mada DHT is used at the soffit to support the wall studs. Mada's DHT features knurled faces which is the pattern of small ridges formed on the Track to prevent screws from slipping and damaging the board, without compromising the strength or thickness of the steel Mada Deflection head Track are used at the soffit to support the wall studs.

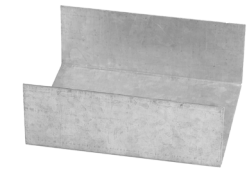

#### Mada Fixing Channel

Mada Fixing Channel is primarily used to support the horizontal cut joints of Plasterboards. It is also used for bracing twin frame wall system. In addition it is also used to support medium to heavy weight fixtures.

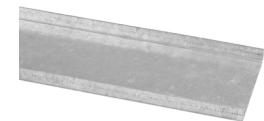

#### Mada Flat Strap

Mada Flat Strap is produced from cold rolled galvanized steel coils. They are primarily used to cover up the horizontal cut joints of gypsum boards. They are also used for bracing twin frame wall system. They are also used to support medium to heavy weight fixtures.



#### Mada MAXI-TEC®

Mada MAXI-TEC® is the latest technology in drywall systems. Mada MAXI-TEC® is our solution to a world where green buildings, carbon footprints, and LEED projects are gaining more popularity and importance. With the revolutionary MAXI-TEC® range of Wall Studs profiles, Mada Gypsum Company and Protektor shows how ecology, economy and ergonomics can be ideally combined in all areas of dry wall construction systems.



Our products are tested/certified by world renowned testing agencies



Intertek



مستأجر  
ALHCTY  
STANGER

## 3.2 Shaft Profiles

### Mada CH Stud

Mada CH Stud is used to form the vertical elements of a shaft wall structure braced into horizontal head and bottom J-Tracks. The CH Studs are designed to provide friction-fit contact for 25 mm Shaft Board as shaft liner

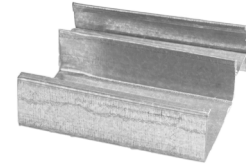

### Mada E Stud

Mada E Stud is used for starter stud, intersection, door opening and end studs in a shaft wall. A 25 mm gap between the flanges allows friction-fit contact for the 25 mm Shaft Board as shaft liner.

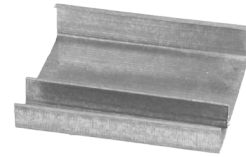

### Mada J Track

Mada J Track is forming the Horizontal element of a shaft wall structure into which the vertical CH-Studs and E-Studs are fixed.

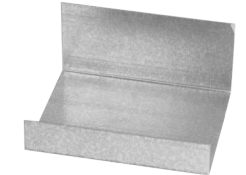

### Mada J Deflection Head Track ( J - DHT )

Mada J - DHT is forming the Horizontal element of a shaft wall structure into which the vertical CH-Studs and E-Studs are fixed. It provides a friction fit for the stud and also provide a slip joint to allow any movement of the structure. It is positioned at the top to guide CH-Studs.

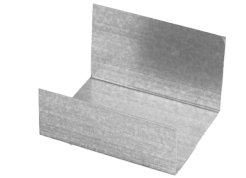

## 3.2 Ceiling Profiles

### Mada Main Channel

Mada Main Channel forms the primary frame of the drywall ceiling framework. It is suspended from the ceiling Soffit using hooked wire, adjustment clip or rigid hangers.



### Mada Furring Channel

Mada Furring Channel is designed to furr-out any surface for application of final finish. It forms the secondary frame of the drywall ceiling framework. It can also be used for drywall lining system.



### Mada Wall Angle

Mada Wall Angle forms the periphery of the drywall ceiling framework. It is fixed to the wall with the help of anchors & serves as support for intermediate channels.

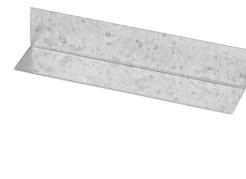

## 4. MADA FINISHING

### 4.1 Accessories

#### Mada Fiber Joint Tape

Mada Fiber Joint Tape is composed of twisted strands of fiber glass woven at right angles to one another for reinforcing drywall joints. It is suitable for hand or mechanical application with Mada's Jointing Compound.



#### Foam Seal Strip

Foam Seal Strip is a self adhesive sealing stripe used as the seal between the perimeter wall studs & wall tracks and background to break flanking sound transmission.



#### Backing Rod

Backing Rod is a round foam rod primarily used as a backing strip for the expansion joints or as gap filler for any open joints so caulking can be applied to finish filling the void and create air-tight, water-tight seal.



#### Mada Fire Guard Sealant

Mada Fire Guard Sealant is developed for use as a joint seal in drywall systems and through penetration fire stop systems. As an acrylic based caulk with a tenacious bond regardless of porosity, it is easy to use on virtually any job. Mada Fire Guard Sealant has a long shelf life and good open time. It is Water, Chemical Resistant (Mild Chemical) and also contains anti-microbial protection to inhibit the growth of mold & mildew. It can be painted & can be applied with all commonly available hand-gun equipment.



#### Mada Jointing Compound

Mada Jointing Compound contains vinyl binders and other ingredients that provide performance superior to that of ordinary ready mix products, blended to creamy smooth consistency. It gives excellent slip and bond and ease workability. It can be used directly from the pail and require minimal mixing thinning and re-tempering.





### Mada PROCEM Cement Jointing Compound

Mada PROCEM Cement Jointing Compound is a 2 component high adhesion, high flexibility Jointing material of which part A is a powder based on special cement & part B is a liquid based on acrylic polymer, fiber and special additives. It is used for jointing and finishing of Mada PROCEM cement board.



### Mada L Bracket

Mada L Bracket is used at the floor and soffit to support the C - studs. Its simple shape of L is rigid enough to resist moments & shear to an extent. One arm of L is fixed to a vertical surface (C- stud) and other projecting horizontally fixed to the support such as wall, ceiling or slab. These brackets are suitable in application of framing for wall lining, bulkheads & ceilings having large suspension drop.

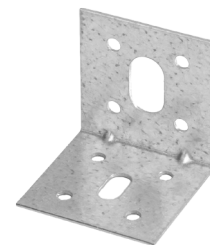

### Mada Slotted L Bracket

Slotted L Brackets is designed typically for both Internal & External applications to resist high moment & shear due to excessive loading (Live load, Seismic & Wind). The vertical slots on the bracket allows to take deflection for slab.



### Mada External Corner Bead:

Mada External Corner Bead is used for straight, durable, corrosion and impact resistant protection to the edges and corners of drywall systems. It is concealed with Mada joint compound to deliver a smooth finished corner.

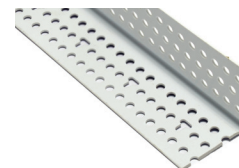

### Mada Casing Bead:

Mada Casing Bead is squared corner beads that fit firmly over the edge of the plasterboard for protection against impact. A range of casing beads are available to fit different plasterboard thicknesses.

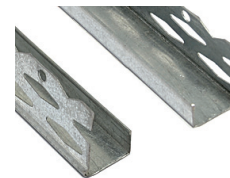

### Mada Shadow Gap Angle Bead:

Mada Shadow Gap Angle Bead provides straight and neat finishing details for internal corners of the drywall ceiling system.

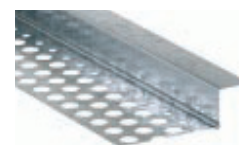

### **Control / Expansion Joint Bead:**

Control / Expansion Joint Bead is used for area where there is a long continuous wall ( > 9.1 m ). It is used to prevent the cracks which can occur through the expansion and contraction of material due the variation in temperature, moisture etc.



### **Rockwool Insulation**

Rockwool is an insulating material manufactured from natural minerals mainly basalt which is melted at very high temperature and spun using advanced production techniques. The fibers are then bonded with minimum quantity of thermosetting resin binder and special additives. It has good Thermal & Acoustic properties, Rock wool is light in weight, strong, re-silent, and easy to handle and cut to suit intricate shapes.



Rockwool is non-combustible in accordance with BS 476 Part 4. Rockwool are free from gases such as CFC, HCFC any other Ozone Depletion material. It is Rot-proof, non-hygroscopic, will not sustain vermin and will not encourage growth of bacteria, mold or fungi.

### **Glasswool Insulation**

It is an insulating material which consist of fine, long, inorganic fibers bonded together by high temperature binder. It has good acoustic properties, light weight, high tensile strength and exceptional resilience. Glasswool Insulation is non corrosive to metal and does not support mold growth.



Glasswool is chemically inert, non-combustible in accordance with BS 476, with flame spread < 25, Smoke developed < 50. It is inorganic. It is Rot proof and odorless.

### **Mada Access Panel**

Mada Access Panel is gypsum based built in accessories for Mada Plus drywall systems. Mada Access Panel is great for allowing access to service areas for plumbing, electrical, security systems, telephone, computer cables, sprinkler systems and more. It is planted in various areas of the suspended ceilings, shaft walls or dry wall partitions that require access for constant adjustments, inspections and revisions.



## 4.2 Drywall Screws

Mada provides a complete range of drywall screws for the fixing of Mada boards to the metal framing. Mada Screws are produced from corrosion protected hardened steel and complying with ASTM C 1002 and ASTM C 954 respectively.

### Mada Self Tapping Screw

Mada Self Tapping bugle head screws have the ability to advance while creating its own thread. It is used for fastening drywall on steel structures below 0.8mm thickness.



### Mada Self Drilling Screw

Mada Self Drilling bugle head screws also known as Tek screws; eradicate the need for a pre-drilled hole and allow drilling and tie to be done in the same motion. It is used for fastening drywall and on steel structures from 0.8mm up to 3.0mm thick.



### Mada PROCEM Self Drilling Screw

Mada PROCEM Self Drilling screws are special corrosion protected screws with countersunk head and ribs under head for fixing of Mada PROCEM cement boards to the metal framing.



### Mada Wafer Head Screw

Mada Wafer Head Screws are used for fixing together metal framing members.



### Mada Hex Head Self Drill Screw

Mada Hex Head Self Drill Screws are used to fasten metal to metal or metal to other accessories from 0.8mm to 3.0mm thickness. It has excellent tensile strength.



## 4.3 Anchors

### Wedge Anchors

Wedge Anchors are made from galvanized steel and have multiple use in non structural cracked and non cracked concrete. They are specially used for fixing of hangers, brackets, and all kinds of drywall profiles to concrete slab where high work load, safety and rigidity of the installation is required.



### Drop in Anchor

Drop-In Anchor is an all steel, medium duty, displacement setting, expansion anchor designed to provide a permanent anchorage point in concrete. Its internal thread allows it to be used with both machine bolts and threaded rod, placing no restrictions on fixture thickness.



### Trubolt Anchor

Trubolt Stud Anchor is a true-to-size, heavy duty, torque controlled expansion anchor, for permanent anchoring into concrete.



### Driva Anchor

Driva Anchor is used for screwing without pre-drilling, directly in to the Plasterboard wall lining.



### Plastic Nail Plug

Plastic Nail Plug is a non-load bearing hammering fixing of the perimeter Tracks and Studs to the solid background (concrete, masonry)



### Mada C – Clamp

Mada C-Clamp is designed to hold primary ceiling channel to soffit by means of threaded rod. This C-Clamp can accommodate 38mm & 45mm Mada Main channels.

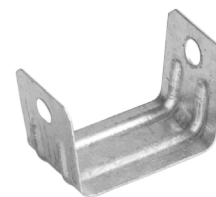

### Threaded Rod

It is designed to be used in high tensions. The Threaded rod features thread along the entire length. Threaded rods are used to suspend ceilings with one end fixed to the concrete slab / Beams or any other structure with suitable fixings and the other end to the ceiling framework.





## 4.4 MADA PLASTERS

MGC has a total stucco capacity of around 400,000 tons per year. MGC operates state of the art Claudius Peters and Grelbex calcinations machines, which allows providing wide range of plasters setting time options as well as other properties.

### STANDARD PLASTER

Mada Standard Plaster is gypsum molding powder product for interiors. It is used for molding of decorations, cornices, repair works, and for modeling. Mada Standard Plaster comes in a wide range of setting time options including 5-15; 7-21; 15-45 mins of initial and final setting time.



### FRENCH PLASTER

Mada Molding French Plaster is a special decorative molding gypsum plaster for interiors and exteriors. It is used for molding of decorations, cornices, repair works, and for modeling.



### FRENCH ADHESIVE

Mada French Adhesive is a special gypsum product for interiors and exteriors. It is used for adhering of decorations and cornices to the wall and for special cladded walls where gypsum boards are glued to the walls.



| Type             | Color           | Mixing                         | Workability (Minutes)       | Duration of work (Minutes) | PH  | Storage                 |
|------------------|-----------------|--------------------------------|-----------------------------|----------------------------|-----|-------------------------|
| Standard Plaster | White           | 17L of water/25KG of Plaster*  | IST: 5 – 15<br>FST: 15 – 45 | 15**                       | 6-7 | 3 months dry conditions |
| French Plaster   | Brilliant White | 27L of water/40 KG of Plaster* | IST: 5 – 15<br>FST: 15 – 45 | 30**                       |     |                         |
| French Adhesive  | White           | 17L of water/25KG of Plaster*  | IST: 30<br>FST: 90          | 60**                       |     |                         |

\*Figures are approximate

\*\*Values can vary depending on thickness of filling/smoothing plaster

IST: Initial Setting Time

FST: Final Setting Time

## 4.5 Mada Renders

Mada Renders are the perfect solution for indoor finishing. Being gypsum based, it shares the same advantages as the plasterboard. They are easy and quick to apply, multitude of use, atmosphere control, fire resistant, and aesthetic. MGC offers three types of renders, Thin Coat, Hand Applied, and Machine.

### Thin Coat Render :

Mada Thin Coat Render is the perfect solution to create thin surfaces perfectly suitable to apply the finishing on. The thin coat render is a single layer smooth-coat render of grey-white color intended for hand processing. Being cost efficient, easy to use, and is less time consuming than cement render, this makes the thin coat render the perfect solution for creating 3-6 mm thick layers.



### Hand Applied Render:

Mada Hand Applied Render is your go-to product for projects that require versatile thicknesses of renders within small areas. The Hand Applied Render is a mixture of hemihydrates calcium sulfate, calcium hydrate, perlite and various additives that improve its workability and surface adhesion. Being quick to prepare, efficient, and versatile, this makes the Hand Applied Render the perfect solution for creating 5-30 mm thick layers.



### Machine Render:

Mada Machine Render is our solution for covering big areas using regular plastering machines. By slightly changing the chemical formula of our other render, the Machine render is designed to have higher thicknesses and handle more weight. The Machine Render has a higher application period, and with the other advantages mentioned, this makes the Machine Render perfect for creating layers starting from 6 mm over a large area.



|              | Color      | Mixing ratio with water    | Working period             | Thickness   | Coverage                       | Tensile strength | Compression strength | Adhesive strength | Diffusion resistance factor | PH level |
|--------------|------------|----------------------------|----------------------------|-------------|--------------------------------|------------------|----------------------|-------------------|-----------------------------|----------|
| Thin Coat    |            | Approx. 1.2 kg per 1L      | Approx. 60 – 90 minutes    | 3-6 mm      | 0.9 kg / m <sup>2</sup> / 1 mm |                  |                      |                   |                             |          |
| Hand Applied | Grey-white | Approx. 1.6 kg per 1 L     | Approx. 60 – 90 minutes    | 5-30 mm     | 0.8 kg / m <sup>2</sup> / 1 mm | ≥ 1.0 mpa        | ≥ 2.5 mpa            | ≥ 0.5 mpa         | μ = 10                      | 7        |
| Machine      |            | Approx. 1.5–2.0 kg per 1 L | Approx. 120 to 150 minutes | 6 or higher | 1 kg / m <sup>2</sup> / 1 mm   |                  |                      |                   |                             |          |

Our products are tested/certified by world renowned testing agencies



# APPROVALS & REFERENCES



**Project:** Kingdom Tower  
**Client:** Kingdom Holding Company  
**Consultant:** Dar Al Handasah  
**Contractor:** Saudi Bin Ladin Group ABCD  
**CITY:** Jeddah

**Project:** SANG Hospital  
**Client:** National Guard Health Affairs  
**Consultant:** Dar Al Handasah  
**Contractor:** Nesma & Partners  
**CITY:** Taif& Qassim



**Project:** Sail Tower Project  
**Client:** AMIAS  
**Consultant:** Dress & Sommer  
**Contractor:** Al Saad General Contracting /  
 BESIX Saudi  
**CITY:** Jeddah

**Project:** Madinah Hajj City  
**Client:** Dar Al Hijra  
**Consultant:** Dar Al Handasah  
**Contractor:** Al Fouzan Contracting  
**CITY:** Madinah





**Project:** Marriott Hotel  
**Client:** Hokair Group  
**Consultant:** Hokair Group  
**Contractor:** SCC  
**City:** Jeddah

**Project:** King Abdullah University Of Science and Technology  
**Client:** KAUST Engineering & Project Management  
**Consultant:** Kirksey Architecture  
**Contractor:** Nesma & Partners  
**CITY:** Thuwal



**Project:** King Faisal University Campus  
**Client:** King Faisal University  
**Consultant:** Abdullaj Al Saif & Partners  
**Contractor:** Azmeel  
**CITY:** Dammam

**Project:** Jabal Omar Development  
**Client:** Jabal Omar Development Company  
**Consultant:** Saudi Consolidated Engineering Company (Khatib & Alami)  
**Contractor:** Nesma & Partners  
**CITY:** Makkah







**Project:** King Abdul-Aziz International Airport  
**Client:** General Authority for Civil Aviation  
**Consultant:** Dar Al Handasah  
**Contractor:** Saudi Bin Ladin Group ABCD  
**CITY:** Jeddah

**Project:** King Abdullah Petroleum Studies & Research Center  
**Client:** Saudi Aramco  
**Consultant:** Zaha Hadid (UK)  
**Contractor:** Drake & Scull International, Saudi Arabia  
 SK Engineering & Construction  
**CITY:** Riyadh

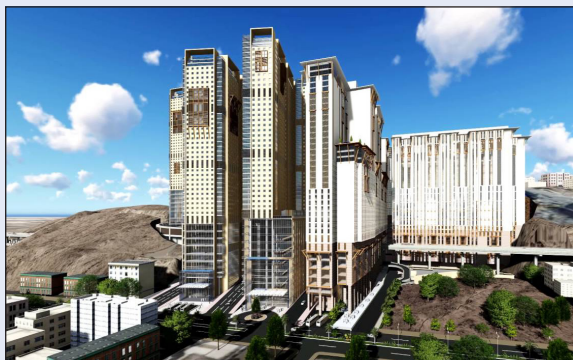

**Project:** MAAD Towers  
**Client:** Maad International Co.  
**Consultant:** Zuhair Fayeze Partnership  
**Contractor:** Ashi & Bushnag Co. Ltd  
**CITY:** Makkah

**Project:** King Abdullah Sport City  
**Client:** Saudi Aramco  
**Consultant:** Orascom Construction Industries (OCI), Saudi Arabia / Arup, UK / Populous (UK)  
**Contractor:** Al Muhaidib / BESIX Saudi / Six Construct Saudi  
**CITY:** Jeddah





**Project:** Burj Vista  
**Client:** EMAAR  
**Consultant:** BHNS Engineering Consultants  
**Contractor:** AGCCIC  
**CITY:** Dubai

**Project:** DAMAC Akoya  
**Client:** DAMAC Properties  
**Consultant:** ATK Engineering Consultants  
**Contractor:** Romeo Interiors LLC  
**CITY:** Dubai

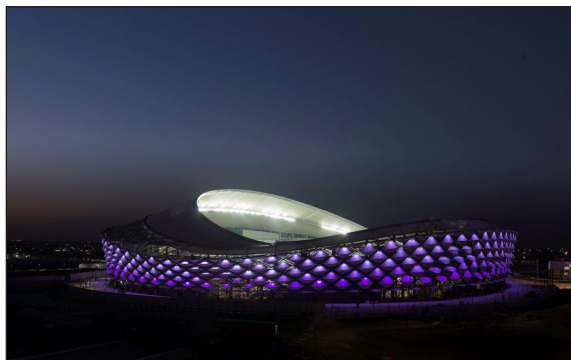

**Project:** Al Ain Stadium & Mixed Use Development  
**Client:** AAFAQ Holding LLC  
**Consultant:** EC Harris International Ltd  
**Contractor:** BAM International Abu Dhabi LLC  
**CITY:** Al Ain

**Project:** Jumeirah Park Villas  
**Client:** Jumeirah Park LLC  
**Consultant:** Dar Al Handasah  
**Contractor:** Arabtec Construction LLC  
**CITY:** Dubai







# WHY mada ?

**ISO Certified**

**World Class Manufacturing Processes in production**

**Latest state of the art process equipment from Gyptech and Grelbex**

**Quality control system, in-house laboratory**

**Products produced according to American ASTM standards**

**Our products comply with European EN standards**

**Best product mix of gypsum boards in GCC**

**Own gypsum rock quarry for best raw material quality control**

**Technical literature to support consultants, architects and specifiers**

## **Head Office**

P.O. Box 31542 , Yanbu Al Sinayah 51000 Kingdom of Saudi Arabia

Tel.: + 966 14 325 3253 / Fax: + 966 14 325 0420

## **Sales & Marketing Office - Saudi Arabia**

Jeddah : Tel.: + 966 12 606 8875, Fax: + 966 12 606 8872

Riyadh : Tel.: + 966 50 643 2561

Dammam & Bahrain: Tel.: + 966 53 333 0480

## **Sales & Marketing Office - Export**

UAE : Tel.: + 971 4 338 0818 - Egypt: Tel.: + 2 012 821 53521

Indian subcontinent: Tel.: +919 76 977 9099 - Other countries: Tel.: + 966 55 536 1370